

220-240V 50 1~**GENERAL DATA**

Application: LBP
Refrigerant: R404A
Evaporating Temperature Range: -40°C to -10°C
Compressor Cooling: Fan
Fan air flow: 800 m³/h
Type: Hermetic reciprocating
Technology Type: On-Off
Expansion Device: Capillary Tube or Expansion Valve
Packing Quantity: Multi - 36 pcs
Displacement: 34.4 cm³
Horse power: 1.5 hp

Approvals:    

MECHANICAL DATA

Bore: 42.85 mm
Stroke: 23.85 mm
Oil Charge: 750ml +/-15ml
Free Internal Volume: 3.9 cm³
Maximum Recommended Refrigerant Charge: 800 g
Oil Type Configuration: Polyolester
Oil Type Viscosity: ISO22
Compressor pressurization: Dry air charge
Weight: 22.8 kg

ELECTRICAL DATA

Motor Type: CSR
Starting Torque: HST
Voltage working range at 50 Hz: 198-254 V
Maximum Motor Temperature: 130 °C
Start Winding Resistance: 4.84 Ω (± 10%) at 25°C
Run Winding Resistance: 1.7 Ω (± 10%) at 25°C

MOUNTING ACCESSORIES

	Description	Code
Cover:	yes	2075281
Terminal Board:	no	-
Anchorage:	no	-
Overload Protector Bracket:	no	-
Capacitor Bracket:	no	-
Grommets:	yes	2221004
Sleeves:	yes	2222016
Washer:	no	-
Pin:	no	-
Clip:	no	-
Rotolock valve:	no	-

ELECTRICAL COMPONENTS

	Component type	Description	Code
Starting Device:	Potential relay	RVA3AN3C-647	1253026
Start Capacitor:		88-108 MFD 330V	2252269
Run Capacitor:		20 MFD	2253312
Motor Protection:	Internal	15HM1963	
CSR / CSIR Box:	yes		1272373

EXTERNAL CHARACTERISTICS

Base Plate: Large
Tray Holder: No
Height: 276 mm

	Internal Diameter (mm)	Material	Shape
Suction Connector	12.77	Copper	Vertical
Discharge Connector	8	Copper	Slanted 65°
Process Connector	6.42	Copper	Vertical



RATED POINT DATA

Cooling Capacity (W)	Power Consumption (W)	Current Consumption (A)	Gas Flow Rate (kg/h)	Efficiency (W/W)
±5%	±5%	±5%	±5%	±7%
1 553	1 158	5.80	35.93	1.34

Test condition: ASHRAE, Fan, Return Gas 32.2°C, Evaporating: -23.3°C, Condensing: 54°C, Ambient: 32.2°C, Liquid: 32.2°C

PERFORMANCE CURVE DATA

220V 50Hz

Condensing Temperature (°C)	Evaporating Temperature (°C)	Cooling Capacity (W)	Power Consumption (W)	Current Consumption (A)	Gas Flow Rate (kg/h)	Efficiency (W/W)
		±5%	±5%	±5%	±5%	±7%
35°C	-10	3 299	1 496	7.37	77.86	2.20
	-15	2 703	1 334	6.63	63.37	2.03
	-20	2 172	1 181	5.92	50.61	1.84
	-25	1 706	1 036	5.26	39.54	1.65
	-30	1 304	901	4.66	30.10	1.45
	-35	967	774	4.13	22.25	1.25
	-40	694	656	3.66	15.92	1.06

Condensing Temperature (°C)	Evaporating Temperature (°C)	Cooling Capacity (W)	Power Consumption (W)	Current Consumption (A)	Gas Flow Rate (kg/h)	Efficiency (W/W)
		±5%	±5%	±5%	±5%	±7%
45°C	-10	3 055	1 596	7.75	71.96	1.91
	-15	2 498	1 413	6.92	58.45	1.77
	-20	1 998	1 238	6.14	46.47	1.61
	-25	1 555	1 070	5.40	35.97	1.45
	-30	1 168	910	4.72	26.90	1.28
	-35	837	758	4.09	19.22	1.10

Condensing Temperature (°C)	Evaporating Temperature (°C)	Cooling Capacity (W)	Power Consumption (W)	Current Consumption (A)	Gas Flow Rate (kg/h)	Efficiency (W/W)
		±5%	±5%	±5%	±5%	±7%
55°C	-10	2 780	1 665	8.08	65.36	1.67
	-15	2 273	1 470	7.20	53.06	1.55
	-20	1 813	1 282	6.35	42.08	1.42
	-25	1 403	1 100	5.55	32.39	1.28
	-30	1 040	925	4.80	23.91	1.12

Test condition: ASHRAE, Fan, Return Gas 32.2°C, Ambient: 32.2°C, Liquid: 32.2°C

ASSEMBLY INSTRUCTION

WIRING DIAGRAM

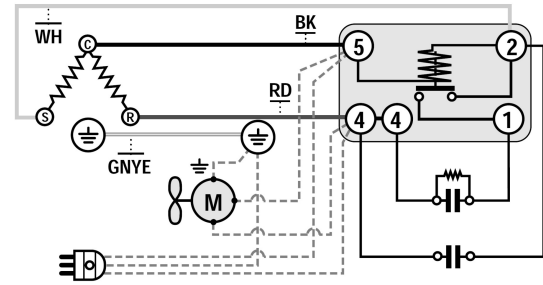
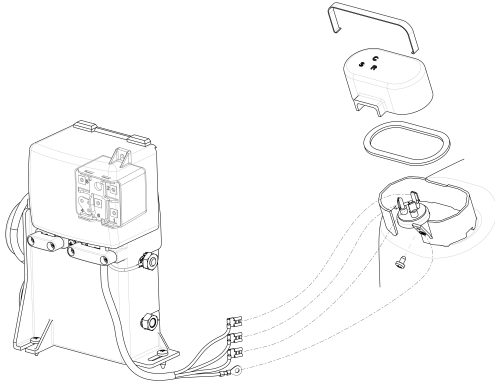

OPERATING ENVELOPE

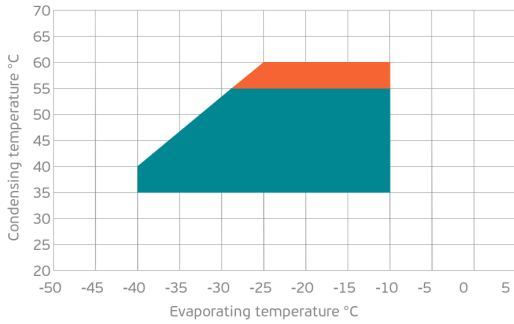

- Operating Condition
- Transient Condition
- Superheating

NOTE: usage of compressors outside of intended working range cannot make use of the warranty, or should be consulted with Technical support.

